

3 CHANNEL, LARGE BAND HEAD AMPLIFIER FOR VCR

PLAY-BACK MODE

- LOW NOISE PERFORMANCE
- LARGE BANDWIDTH (SVHS PROCESSING CAPABILITY)
- AUTOMATIC OFFSET CANCELLER BETWEEN TWO SELECTED HEADS
- RECORD AMPLIFIER INHIBITION DURING PLAYBACK
- DIRECT DRIVE OF COAXIAL CABLE (500Ω - 100pF) OF PLAY-BACK OUTPUT

RECORD MODE

- INTEGRATED I/I CONVERTER WITH AUTOMATIC CONTROL OF TRANSCONDUCTANCE
- AUTOMATIC RECORD PLAY-BACK SWITCHING
- PLAYBACK INHIBITION DURING RECORD MODE
- AUTOMATIC PROTECTION OF RECORD AMPLIFIER AGAINST SHORT CIRCUIT

DESCRIPTION

The TEA5701 is an advanced one chip 3 heads record and playback amplifier for VCR.



PIN CONNECTIONS

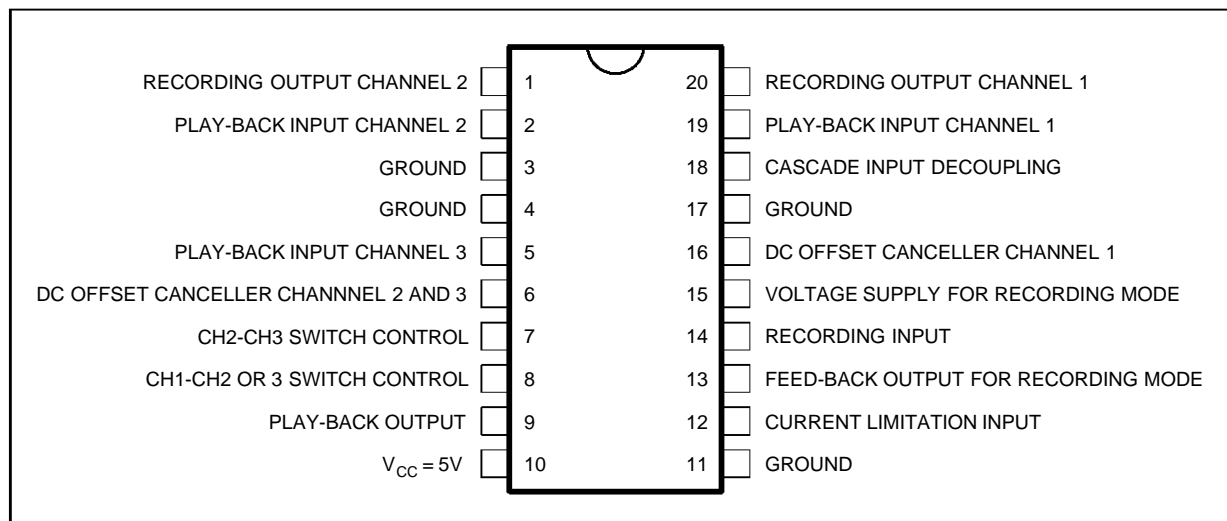

5701-01.EPS

BLOCK DIAGRAM

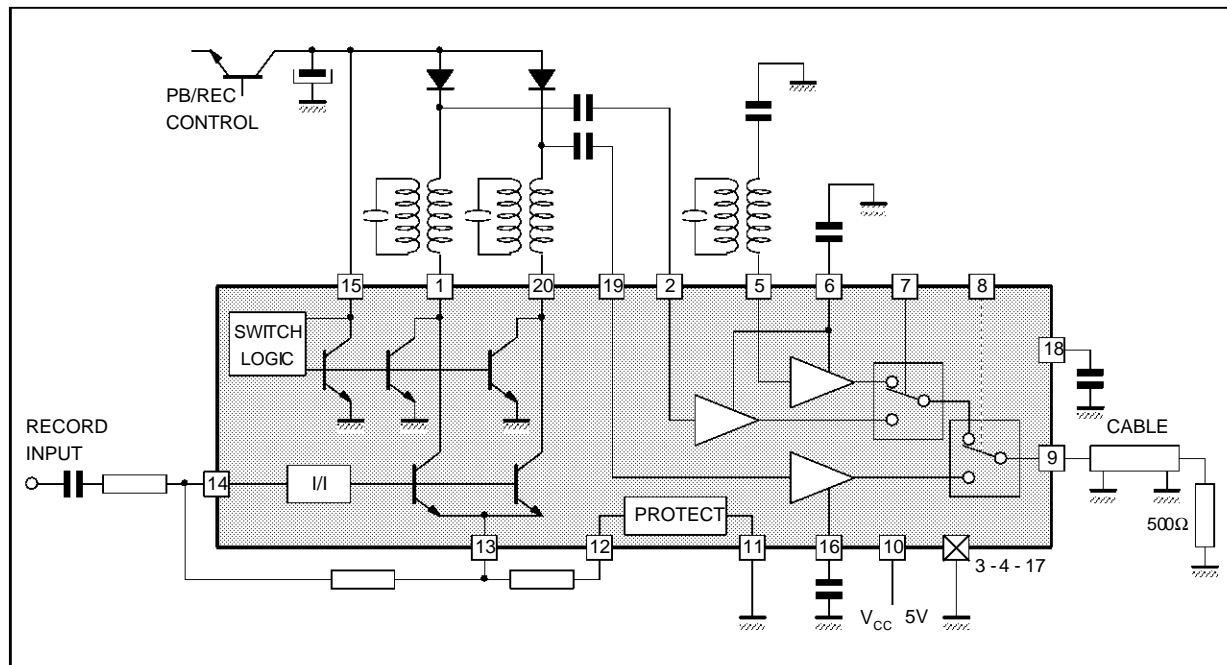

5701-02.EPS

FUNCTIONAL DESCRIPTION

TEA5701 is intended for 3 heads VCR applications. It includes all the electrical functions necessary to achieve playback and record processing for VHS and SVHS applications (9MHz).

High performance technology allows very low noise levels (current and voltage). In playback mode a special feature suppresses the DC offset when switching two channels. Optimized play-back output stage gives to the TEA5701 large capability to drive directly a coaxial cable in order to reduce number of external components.

An automatic scanning of recording supply voltage permits that TEA5701 switches automatically in playback or in record mode. The switching threshold voltage from play-back to record and record to playback is fixed to a value which forbids high current peaking through the heads.

The recording amplifier includes a protection system which protects the IC and the application board against overheating in case of short circuit on the recording transconductance components.

The TEA5701 is fully protected against ESD.

ABSOLUTE MAXIMUM RATINGS

Symbol	Parameter	Value	Unit
V _{CC}	Supply Voltage	6	V
V _{REC}	Supply Voltage	15	V
T _{stg}	Storage Temperature Range	-40, +150	°C

5701-01.TBL

THERMAL DATA

Symbol	Parameter	Value	Unit
R _{th(j-a)}	Junction-ambient Thermal Resistance	70	°C/W

5701-02.TBL

ELECTRICAL OPERATING CHARACTERISTICS

All the operating characteristics are given for ambient temperature 25 °C unless otherwise specified.

Playback Mode

General conditions for play-back : $V_{CC} = 5V$, no load on play-back output

Symbol	Parameter	Test Conditions	Min.	Typ.	Max.	Unit
V_{CC}	Supply Voltage		4.75	5	5.25	V
I_{CC}	Current Supply			45	60	mA
G_{PB}	Play-back Gain	Sine Wave 400mVpp at 600kHz on Pin 9	56	60	63	dB
ΔG_{PB}	Gain Difference Between Three Play-back Channels	Sine Wave 3.8MHz, 0.4mVpp on Pins 2 - 5 - 19		0.3		dB
e_n	Equivalent Input Voltage Noise Level	Measured at 500kHz - CH1 Via Switching Transistor Pin 20 - CH2 Via Switching Transistor Pin 1 - CH3 Grounded		0.4		nV/ \sqrt{Hz}
i_n	Equivalent Input Current Noise Level	Measured at 500kHz - PB Inputs Pins 2 - 5 - 19 not Connected		3		pA/ \sqrt{Hz}
CRT	Crosstalk	Sine Wave 3.8MHz, 400mVpp on Pin 9 For selected channel - CH1 input, between pins 19 and 20 - CH2 input, between pins 1 and 2 - CH3 input, between pin 5 and ground			- 40	dB
FLCPB	Playback Bandwidth Low Cut Off Frequency	Reference Signal Level : Sine Wave 3.8MHz 400mVpp - Play-back Input Capacitors 22nF (pins 2 - 6 - 19) - DC Offset Canceller Capacitor (pins 6 - 16-) 47 nF		20	100	kHz
FHCPB	Playback Bandwidth High Cut Off Frequency	Same Conditions as Above	8	9.5		MHz
C_{in}	Playback Input Capacitance Pins 2 - 5 - 19			50		pF
R_{in}	Playback Input Resistance Pins 2 - 5 - 19			600		Ω
VDCPB	DC Level on Play-back Output Pin 9 during Playback	With 500 Ω Load Resistor Between Pin 9 and Ground	1.9	2.4	2.9	V
ΔVDC	Head Switch Offset Pin 9 (all switches combinations)				50	mV
SM	Second Harmonic on Playback Output Pin 9	Sine Wave 3.8 MHz 400 mVpp with 500 Ω load Resistor		- 43	- 38	dB
V_{sat}	Maximum Voltage on Pins 1 and 20 at Playback Mode	Input Current Pins 1 and 20 20mADC			100	mV

5701-03.TBL

ELECTRICAL OPERATING CHARACTERISTICS (continued)**Recording Mode**

General conditions for recording mode : $V_{REC} = 12V$, $V_{CC} = 5V$, Load resistor 100Ω on pins 1 and 20

No load on play-back output Pin 9

Transconductance network defined by : $R1 = 5.1\Omega$ 1% pins 12-13

$R2 = 1k\Omega$ 1% pins 13-14

$R3 = 750\Omega$ 1% pin 14

Symbol	Parameter	Test Conditions	Min.	Typ.	Max.	Unit
V_{REC}	Recording Supply Voltage		9	12	12.6	V
I_{CCREC}	Current Supply from V_{REC}			50	60	mA
I_{CCI}	Current Supply from V_{CC}			30	37.5	mA
V_{DCREC}	DC Level on Play-back Output Pin 9	With 500Ω Load Resistor between Pin 9 and Ground	3.1	3.6	4.1	V
	Maximum Recording Current on Each Channel	$f = 1.6MHz$	40			mApp
	Maximum Recording Current on Each Channel	$f = 3.8MHz$	35			mApp
g	Transconductance	$R1 = 5.1\Omega$ 0%, $R2 = 1000\Omega$ 0% $R3 = 750\Omega$ 0%, $V_{in} = 300mV_{pp}$ Measured at 500kHz		132		mA/V
Δg	Recording Current Difference Between Pins 1 and 20	Sine Wave 3.8MHz - recording = 30mApp			0.5	dB
REREC	Equivalent Input Resistance			660		Ω
R_s	Output Resistance Pins 1 and 20	$R1 = 5.1\Omega$		100		k Ω
SHREC	Second Harmonic Pins 1 and 20	Output Current on Each Output : 30mApp at 3.8MHz			- 38	dB
FLCREC	Recording Bandwidth Low Cut Off Frequency	Reference Output Current 30mApp at 3.8MHz for - 3dB		20	100	kHz
FHCREC	Recording Bandwidth High Cut Off Frequency	Reference Output Current 30mApp at 500kHz for - 3dB	8	9.5		MHz
	Maximum Input Current Pin 12	Pin 12 Connected to $V_{REC} = 12V$			100	mA
	Maximum Saturation Voltage on Pin12	Input Current Pin 12 : 50mA		100	150	mV
IM	Intermodulation	- Luminance = 30mApp 3.8MHz - Chrominance = 7.5mApp, 600kHz Measured at 3.8MHz \pm 600kHz		- 50		dB

5701-04.TBL

Switching Levels

Symbol	Parameter	Test Conditions	Min.	Typ.	Max.	Unit
V_{H8}	Threshold Voltage for Head 1 Selection on Pin 8		2.4		V_{CC}	V
V_{L8}	Threshold Voltage for Head 2 or 3 Selection on Pin 8		0		1.5	V
I_{H8}	Input Current Pin 8 for H1 Selected	Pin 8 Connected to V_{CC}			50	μA
I_{L8}	Output Current Pin 8 for H2 or 3 Selected	Pin 8 Connected to Ground			- 50	μA
V_{H7}	Threshold Voltage for Head 2 Selection on Pin 7		2.4		V_{CC}	V
V_{L7}	Threshold Voltage for Head 3 Selection on Pin 7		0		1.5	V
I_{H7}	Input Current Pin 7 for Head 2 Selected	Pin 7 Connected to V_{CC}			50	μA
I_{L7}	Output Current Pin 7 for Head 3 Selected	Pin 7 Connected to Ground			- 50	μA
	Switching Time from H1 Selected to H2 Selected	Switching Pulse from 5 to 0V Applied Pin 8		250	500	ns
	Switching Time from H2 Selected to H1 Selected	Switching Pulse from 0 to 5V Applied Pin 8		250	500	ns

5701-05.TBL

ELECTRICAL CHARACTERISTICS (continued)**Switching Levels**

Symbol	Parameter	Test Conditions	Min.	Typ.	Max.	Unit
VRPB	Recording Supply Voltage Threshold (pin 15) for Switching from Record to Playback		0.15	0.3	0.5	V
VPBR	Recording Supply Voltage Threshold (pin 15) for Switching from Playback to record		0.25	0.4	0.6	V
	Delay Time for Suppression of Play-back Output Signal on Pin 9 (playback to record)	See Measurement Conditions End of Paragraph		30		μ s
	Delay Time for Presence of Playback Output Signal on Pin 9 (record to play-back)	See Measurements Conditions End of Paragraph		20		ms
	Delay Time for Suppression of Recording Signals Pins 1 and 20 (record to playback)	See Measurements Conditions End of Paragraph		4		ms
	Delay Time for Suppression of Recording Signals Pin 1 and 20 (playback to record)	See Measurements Conditions End of Paragraph		200		μ s
SVR	Supply Voltage Rejection	Gain Measure Made Between Playback Output Pin 9 and V_{CC} (0.5mVpp on Pin 10)	15	20	25	dB

5701-06.TBL

Test Conditions for Measuring Delay Times (play-back to record and vice versa)

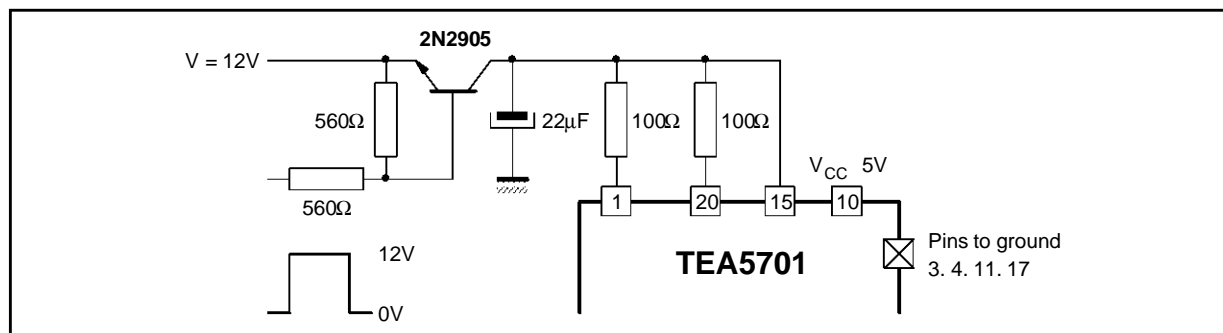

5701-03.EPS

INPUTS/OUTPUTS EQUIVALENT INTERNAL DIAGRAM

Pin 1 And 20

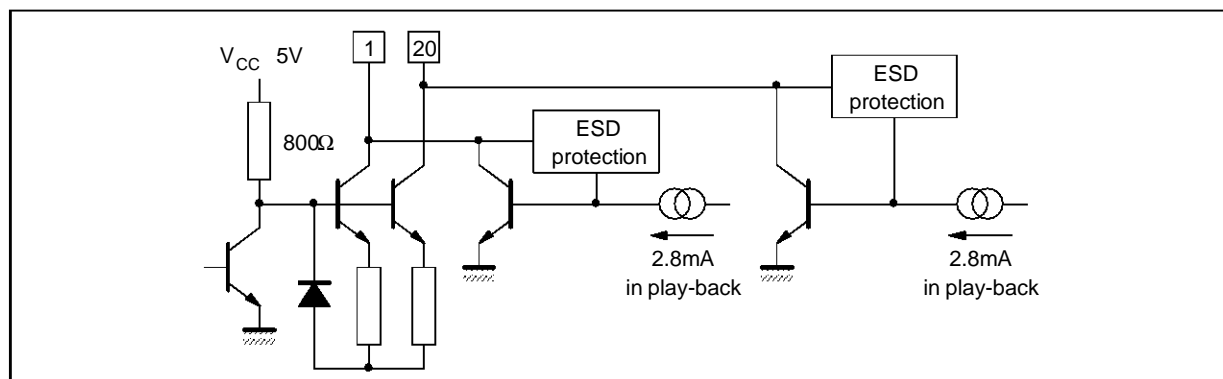

5701-04.EPS

INPUTS/OUTPUTS EQUIVALENT INTERNAL DIAGRAM (continued)

Pin 15

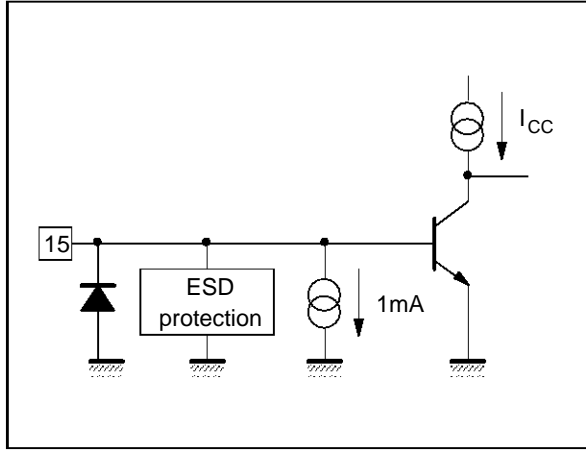

Pins 2 - 5 - 19 - 18

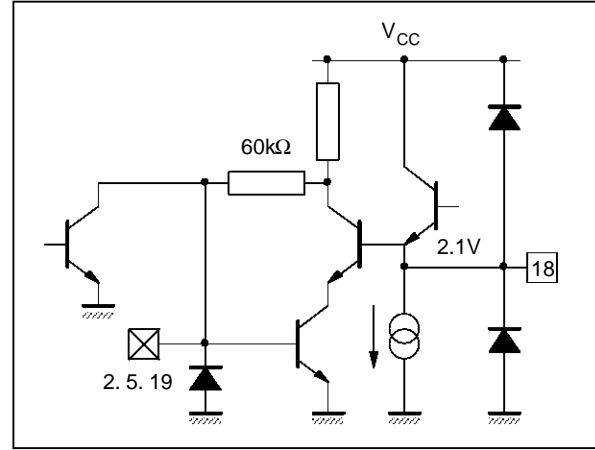

Pins 6 - 16

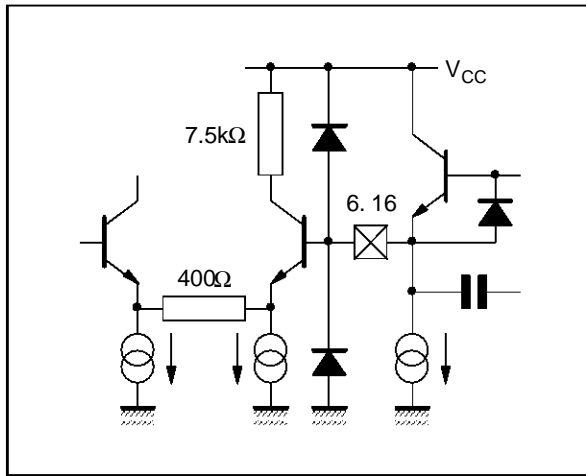

Pins 7 - 8

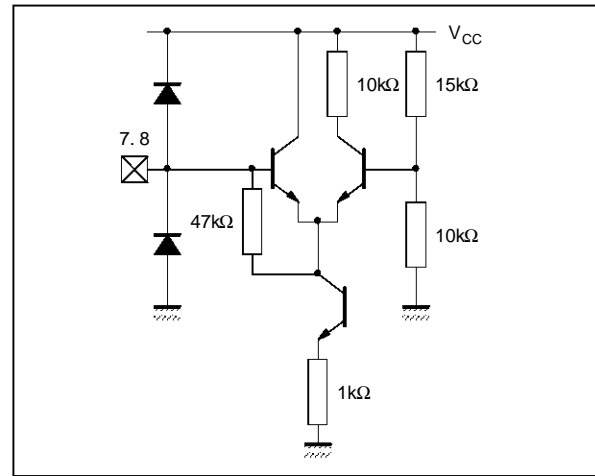

Pin 9

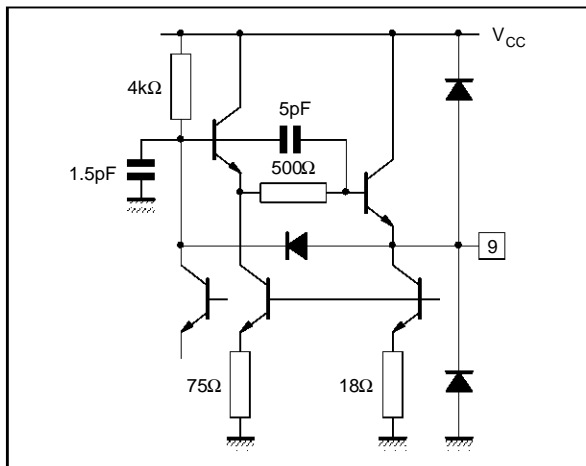

Pin 12

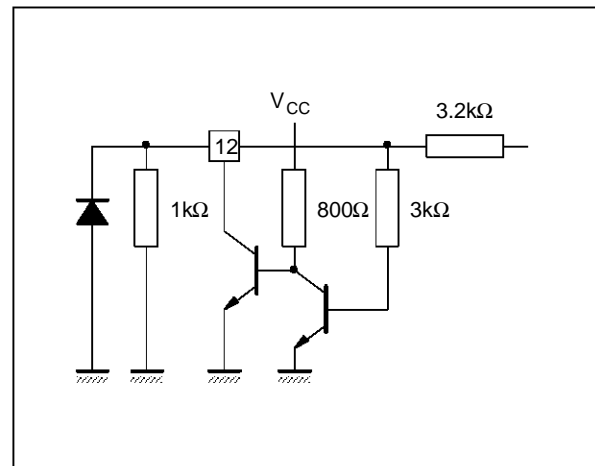

INPUTS/OUTPUTS EQUIVALENT INTERNAL DIAGRAM (continued)

Pin 13

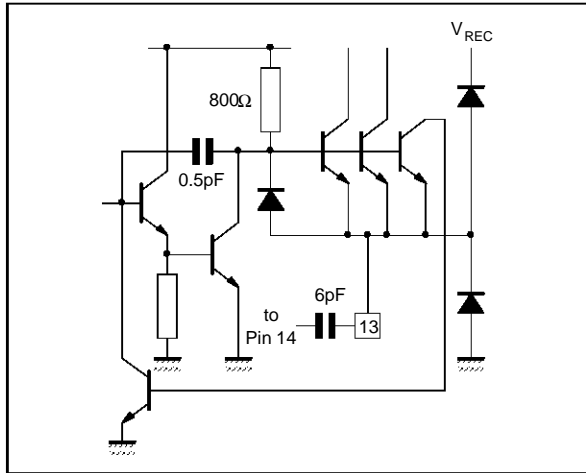

Pin 14

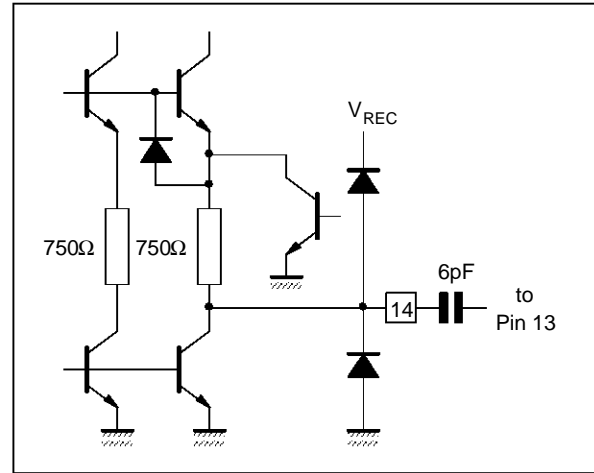

TYPICAL APPLICATION

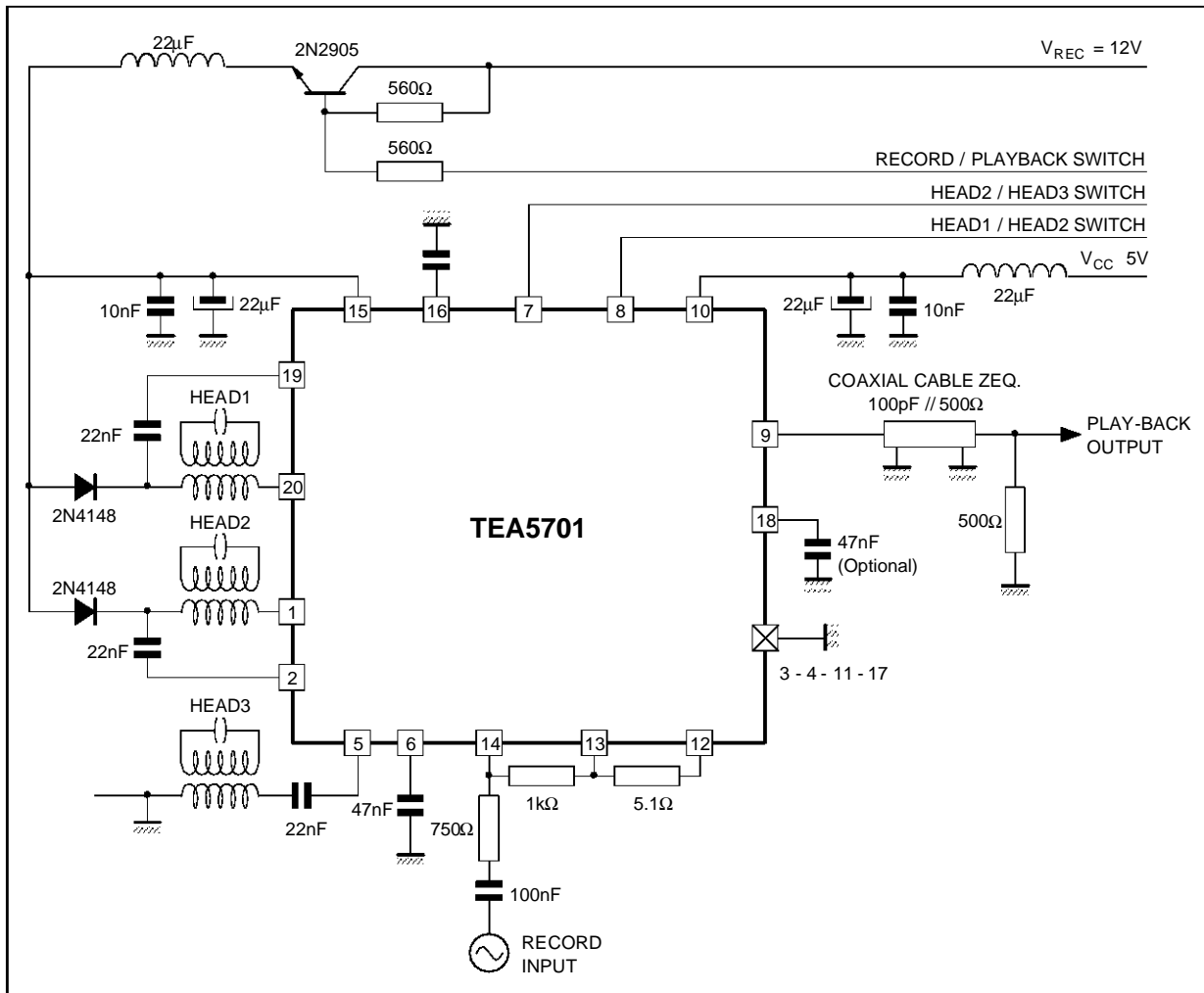

PACKAGE MECHANICAL DATA
SO20 LARGE – PLASTIC MICROPACKAGE

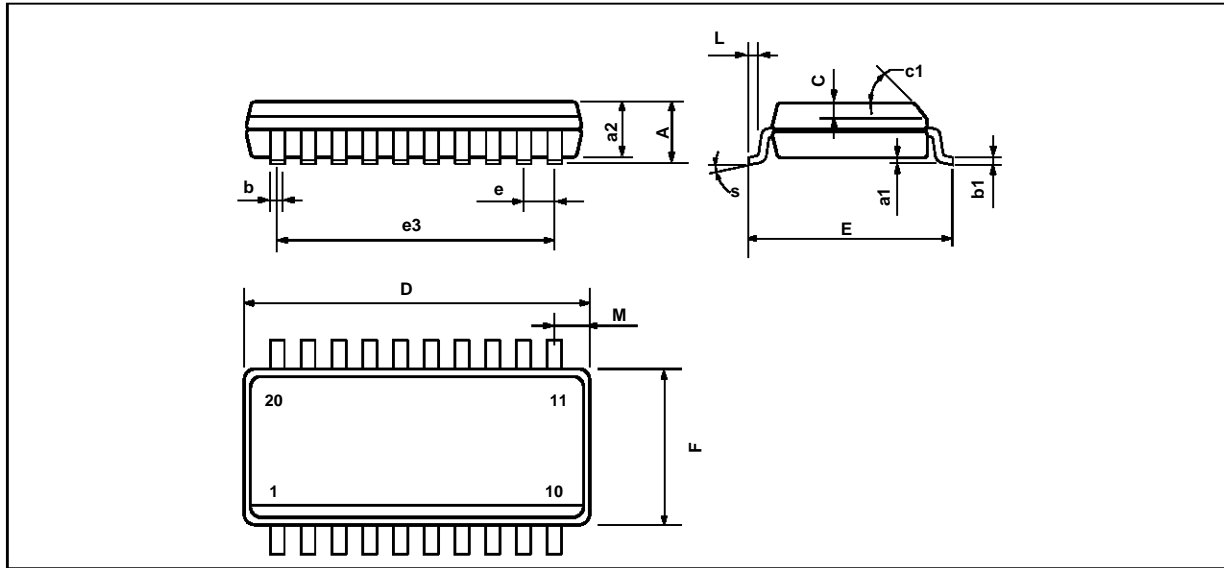

PM-SO20L.EPS

Dimensions	Millimeters			Inches		
	Min.	Typ.	Max.	Min.	Typ.	Max.
A			2.65			0.104
a1	0.1		0.2	0.004		0.008
a2			2.45			0.096
b	0.35		0.49	0.014		0.019
b1	0.23		0.32	0.009		0.013
C		0.5			0.020	
c1	45° (typ.)					
D	12.6		13.0	0.496		0.510
E	10		10.65	0.394		0.419
e		1.27			0.050	
e3		11.43			0.450	
F	7.4		7.6	0.291		0.300
L	0.5		1.27	0.020		0.050
M			0.75			0.030
S	8° (max.)					

SG20L.TBL

Information furnished is believed to be accurate and reliable. However, SGS-THOMSON Microelectronics assumes no responsibility for the consequences of use of such information nor for any infringement of patents or other rights of third parties which may result from its use. No licence is granted by implication or otherwise under any patent or patent rights of SGS-THOMSON Microelectronics. Specifications mentioned in this publication are subject to change without notice. This publication supersedes and replaces all information previously supplied. SGS-THOMSON Microelectronics products are not authorized for use as critical components in life support devices or systems without express written approval of SGS-THOMSON Microelectronics.

© 1994 SGS-THOMSON Microelectronics - All Rights Reserved

Purchase of I²C Components of SGS-THOMSON Microelectronics, conveys a license under the Philips I²C Patent. Rights to use these components in a I²C system, is granted provided that the system conforms to the I²C Standard Specifications as defined by Philips.

SGS-THOMSON Microelectronics GROUP OF COMPANIES

Australia - Brazil - China - France - Germany - Hong Kong - Italy - Japan - Korea - Malaysia - Malta - Morocco
The Netherlands - Singapore - Spain - Sweden - Switzerland - Taiwan - Thailand - United Kingdom - U.S.A.